

Acoustic & Sonic Inc

2298 NW 82 AVE., Doral, FL 33122

Phone: (305) 436-8360 | (786) 423-1756 | Fax:(305) 436 8585

Email: info@acousticsonic.com | www.acousticsonic.com

Resilient Sound Isolation Clip



SOUND ISOLATION WALL AND CEILING

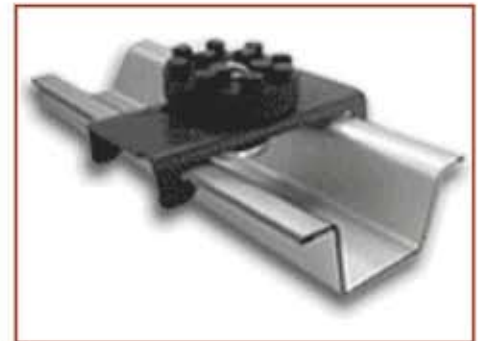
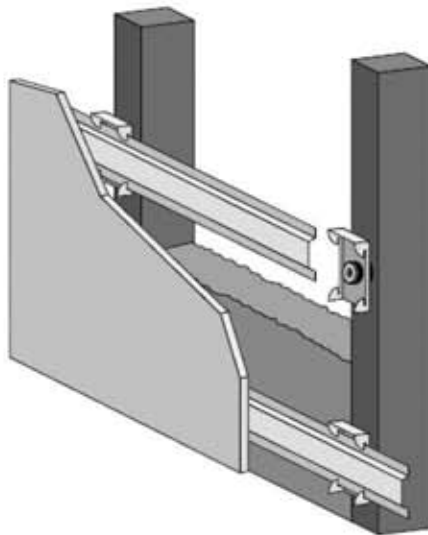

The RSIC-1 is used with Drywall Furring Channel this assembly fastening gypsum wallboard to a supporting structure while simultaneously isolating it from vibration and structural noise from room above, below and alongside.

Acoustic & Sonic Inc

2298 NW 82 AVE., Doral, FL 33122

Phone: (305) 436-8360 | (786) 423-1756 | Fax: (305) 436 8585

Email: info@acousticsonic.com | www.acousticsonic.com

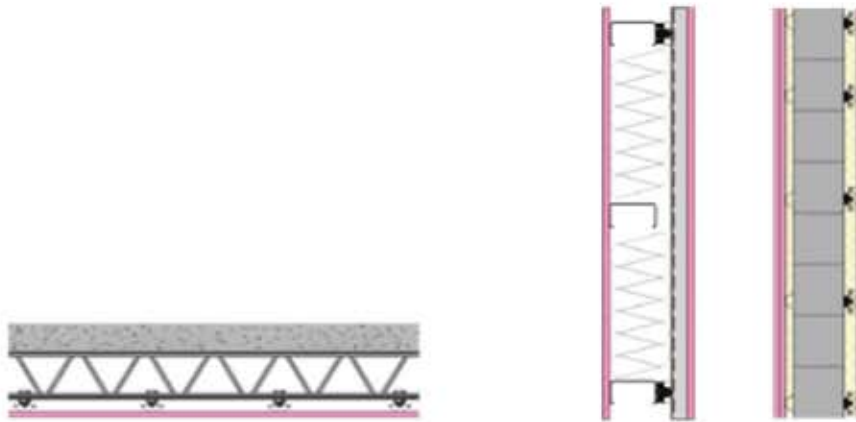

SPECIFICATIONS:

- Resilient Sound Isolation Clip (RSIC-1) shall be 48 inches maximum on center. (horizontal)
- Fasten the Resilient Sound Isolation Clip (RSIC-1) to the the substrate with a fastener approved for a minimum pull-out and shear of 120 lbs.
- Ensure the internal metal ferrell is tight to the substrate. • Locate the first row of RSIC-1 clips within 3 inches from the floor and within 6 inches from the ceiling.
- Snap in the drywall furring channel (hat track) into the RSIC-1 clips (horizontal for walls).
- Place 1/4" (minimum) shim on floor to fully support the gypsum board.
- Install the gypsum board from the bottom up leaving a 1/4" min. gap around perimeter.
- ONLY remove the shims after ALL the gypsum board is completely screwed to ALL the drywall furring channels. Make sure every screw (floor to ceiling and wall to wall) is installed as required by the assembly design, in every layer of gypsum board before removing the shims at the floor. The shims are critical to ensure best results.
- Caulk around the entire perimeter of the gypsum board. Use fire and smoke rated acoustical sealant where required.

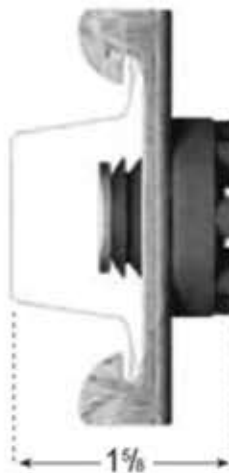

The RSIC-1 has been acoustically tested and adds 15 to 20 STC. Reducing the structural noise by 75 to 100%, the RSIC-1 can be attached to wood, steel or concrete.

Acoustic Sonic Inc.

Acoustic & Sonic Inc

2298 NW 82 AVE., Doral, FL 33122

Phone: (305) 436-8360 | (786) 423-1756 | Fax: (305) 436 8585

Email: info@acousticsonic.com | www.acousticsonic.com

RSIC-1 SOUND ISOLATION CLIP

APPLICATION RECOMMENDATIONS FOR WALLS AND CEILINGS, WOOD OR STEEL FRAMING

INSTALLING RESILIENT SOUND ISOLATION CLIPS (RSIC-1)

RSIC CLIPS AT 24" OC.

RSIC-1 Wall or Ceiling System Framing at 24" o.c.

RSIC-1 clips at 24" x 48" o.c. 1 or 2 Layers of 5/8" Gypsum Board

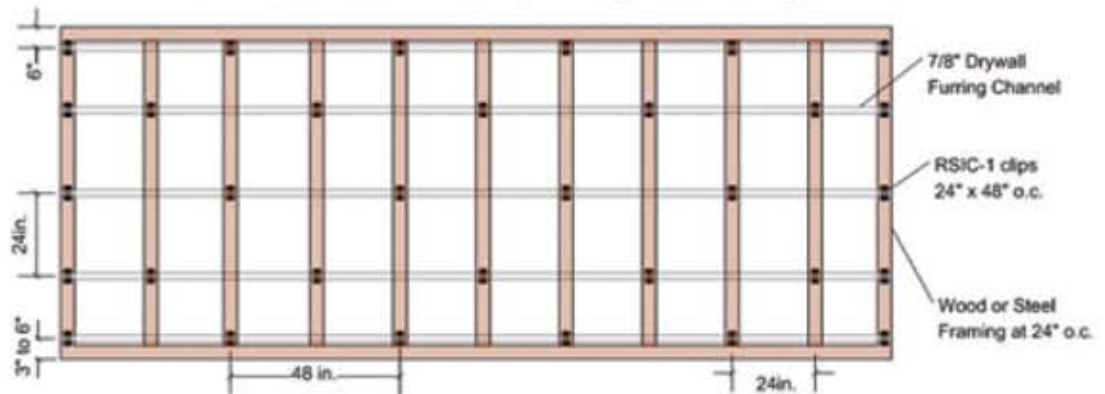

RSIC-1 Wall or Ceiling System Framing at 16" o.c.

RSIC-1 clips at 24" x 48" o.c. 1 or 2 Layers of 5/8" Gypsum Board

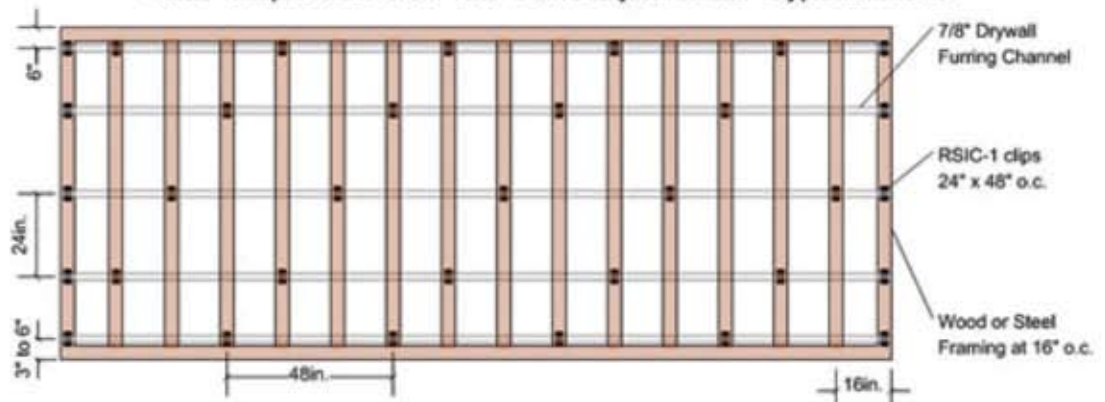

Acoustic & Sonic Inc

2298 NW 82 AVE., Doral, FL 33122

Phone: (305) 436-8360 | (786) 423-1756 | Fax: (305) 436 8585

Email: info@acousticsonic.com | www.acousticsonic.com

RSIC-1 SOUND ISOLATION CLIP

**ESTIMATED RSIC CLIP USAGE FOR WALLS AND CEILINGS,
WOOD OR STEEL FRAMED. (SPACING AT 24" X 48" O.C.)**

	1~4'	5~8	9~12	13~16	17~20	21~24	25~28	29~32	33~36	37~40
1~3'	4	6	8	10	12	14	16	18	20	22
3~5	6	9	12	15	18	21	24	27	30	33
5~7	8	12	16	20	24	28	32	36	40	44
7~9	10	15	20	25	30	35	40	45	50	55
9~11	12	18	24	30	36	42	48	54	60	66
11~13	14	21	28	35	42	49	56	63	70	77
13~15	16	24	32	40	48	56	64	72	80	88
15~17	18	27	36	45	54	63	72	81	90	99
17~19	20	30	40	50	60	70	80	90	100	110
19~21	22	33	44	55	66	77	88	99	110	121
21~23	24	36	48	60	72	84	96	108	120	132
23~25	26	39	52	65	78	91	104	117	130	143
25~27	28	42	56	70	84	98	112	126	140	154
27~29	30	45	60	75	90	105	120	135	150	165
29~31	32	48	64	80	96	112	128	144	160	176
31~33	34	51	68	85	102	119	136	153	170	187
33~35	36	54	72	90	108	126	144	162	180	198
35~37	38	57	76	95	114	133	152	171	190	209
37~39	40	60	80	100	120	140	160	180	200	220
39~41	42	63	84	105	126	147	168	189	210	231

Note: Add 4 RSIC-1 at each drywall butt joint condition for optimum acoustical and UL Fire Resistive assembly compliances. See UL Fire Resistive Design specifications.

Acoustic Sonic Inc.